

1

Mecanización
Machining
Mécanisation

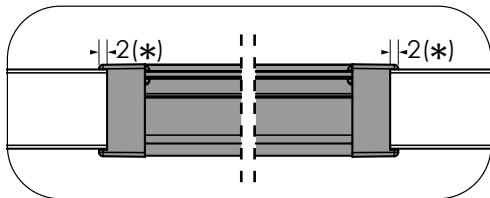

Longitud tirador - número de clips
Handle length - number of clips
Longueurs de poigné - numéro de clips

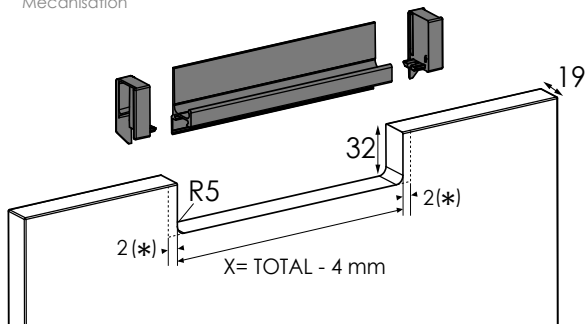
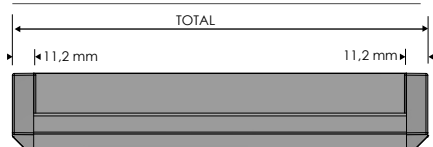

Longitud perfil
Profile length
Longueur profilé = TOTAL - 22,4 mm

2

Aplicar adhesivo
Apply adhesive
Appliquer l'adhésif

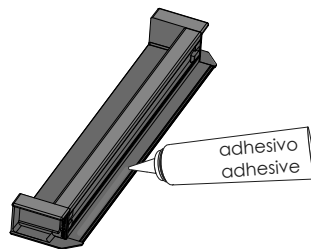

Componentes
Components
Composants



Perfil de Aluminio
Aluminum profile
Profile aluminium

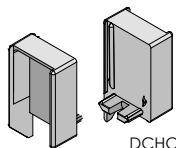

IZDO.
Left
DCHO.
Right

Juego de Terminales
Caps
Embouts

3

Colocar a presión
Press downward
Appuyez vers le bas

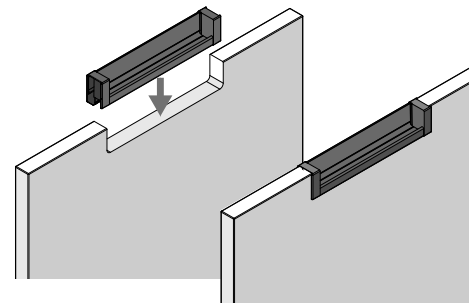

Acabados
Finishes
Finitions

35 plata mate
matt silver
argent mat

04 plata brillo
chrome effect
effet chrome

60 antracita
anthracite
anthracite

50 inox mate - champagne
matt inox - champagne
inox mat - champagne

52/52M negro brillo / negro mate
gloss black / matt black
noir brillant / noir mat

01/01M blanco brillo / blanco mate
gloss white / matt white
blanc brillant / blanc mat

Montaje de terminales | End caps assembly

Encajar el terminal con un martillo de nailon para evitar daños

Assemble end caps using a rubber mallet to avoid damages

Utilisez un mallet en caoutchouc pour installer les embouts et éviter les dommages

